

1

DURA CLUTCH INSTALLATION

15-541 DC-RANGER1000XP-ZE MY21,22

SVI, LLC REV1 05MAY2022

KIT PART #: 15-541

MODEL: DC-RANGER1000XP-ZE

DESCRIPTION: MY21,22 RANGER XP1000 MY21,22 RANGER CREW 1000XP. This model has the Polaris P90X Clutch. See exceptions below.

Does not fit

MY21 RANGER 1000 (Non-XP). These models have the Polaris P190X CLUTCH.

MY22 ALL NORTHSTAR RANGER XP1000 AND XP1000 CREW MODELS. These models have a 6:1 crankshaft taper. These are coming soon.

KIT CONTENTS:

1. 10-174 ASM-DCPRIM WT10-240 SPR50-001
2. 25-146 BUSHING-CLUTCH WASHER
3. 75-047 SCREW-CLUTCH
4. 99-024 TOOL-12MM BIT SOCKET 3/8 DRIVE
5. 99-028 TOOL-T60 BIT SOCKET 3/8" DRIVE
6. 10-221 ASM-DC SECONDARY 9.5 PREM ROLL
7. 35-057 BELT (SUBSTITUTE 3211196)
8. 7556130 SECONDARY WASHER-.406X1.25X.125 BELLE-Y
9. 99-023 LOCTITE 243 0.5ML CAPSULE 1330255
10. 30-091 TOOL-BELT INSTALL 2877408
11. 97-058 DECAL-DC CLUTCH HOUSING DASH 35-057
12. OWNERS MANUAL SUPPLEMENT
13. WEIGHT CHART
14. DURA CLUTCH WARRANTY
15. 98-067 INSTALLATION INSTRUCTIONS 15-541 (THESE INSTRUCTIONS)

DURA CLUTCH INSTALLATION

1. Remove airbox to plenum hose clamps and move hose out of the way.

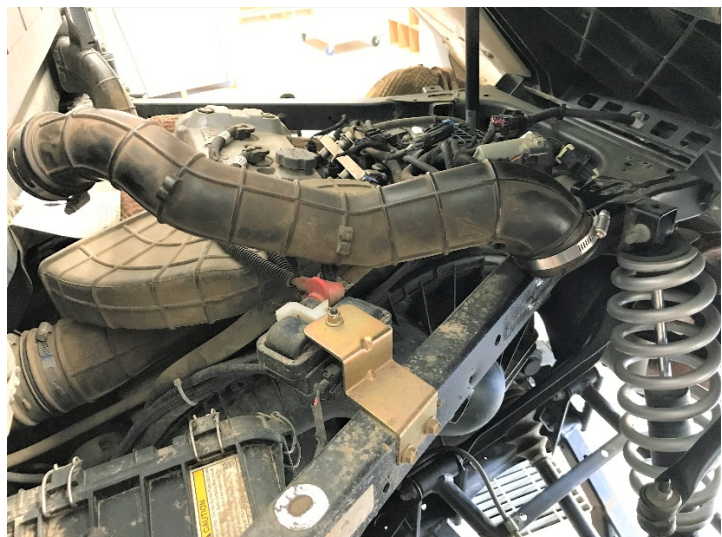
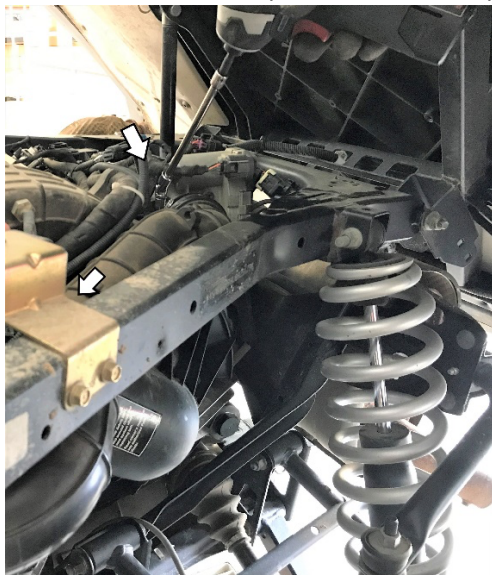

2. Remove the clutch housing cover. Recommended tool: 8mm socket with flex drive extension.

3. Remove Primary clutch bolt. Remove the Polaris primary outer movable sheave assembly. Pull off by hand holding the central shaft in place with your thumb. Move around the clutch, with a pulling and rocking motion.



4. Pull the Polaris primary fixed sheave from the engine crankshaft using PN 99-012 puller. Greasing the end of the puller slightly will aid in removal. Do not get grease on any clutch components.



5. Clean the engine tapered shaft and DURACLUTCH Primary clutch bore with alcohol or degreaser. Do not lubricate.
6. Remove the Secondary clutch.
7. Install DURACLUTCH Secondary using stock bolt and 7556130 Belleville washer provided with kit. Stock shim washers are not used. (see pic below) Place blue Loctite on stock secondary bolt threads and tighten bolt to 27 ft-lbs.

Do not use



How Belleville washer is installed on secondary bolt

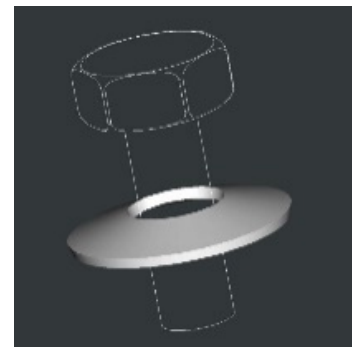

8. Slip the belt into the Secondary so you can read the part number on the belt and using Belt Install Tool open secondary so belt will seat down into clutch. Sometimes a screwdriver is needed to assist tool to seat lower into clutch.



9. Slide belt into primary clutch, then install on post.



10. Install DURACLUTCH Primary hardware provided as shown below. VERY IMPORTANT -Torque bolt to 60 ft-lbf. Over tightening will not allow clutch to operate properly.
11. Once primary is torqued, with transmission in PARK, spin secondary clutch back & forth a few times to allow belt back to top of secondary.

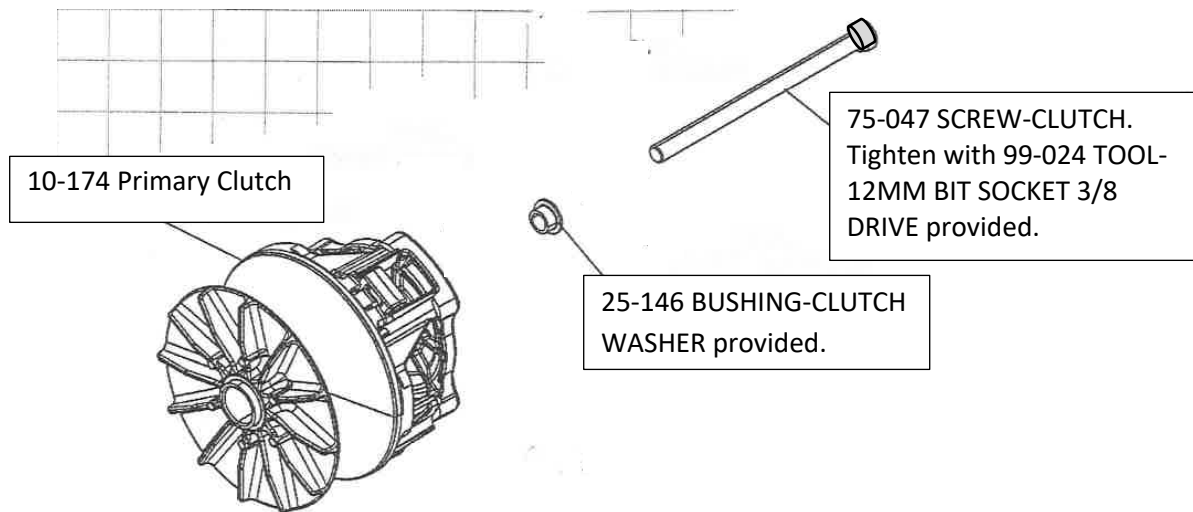

Do not use the original equipment screw or hardware.

12. How to install a Belt if the Primary and Secondary are already installed. Place Belt in the Primary and open the Secondary sheaves with the Belt Installation Tool provided. Roll belt into the Secondary sheaves. Sometimes a screwdriver is needed to seat lower into clutch.

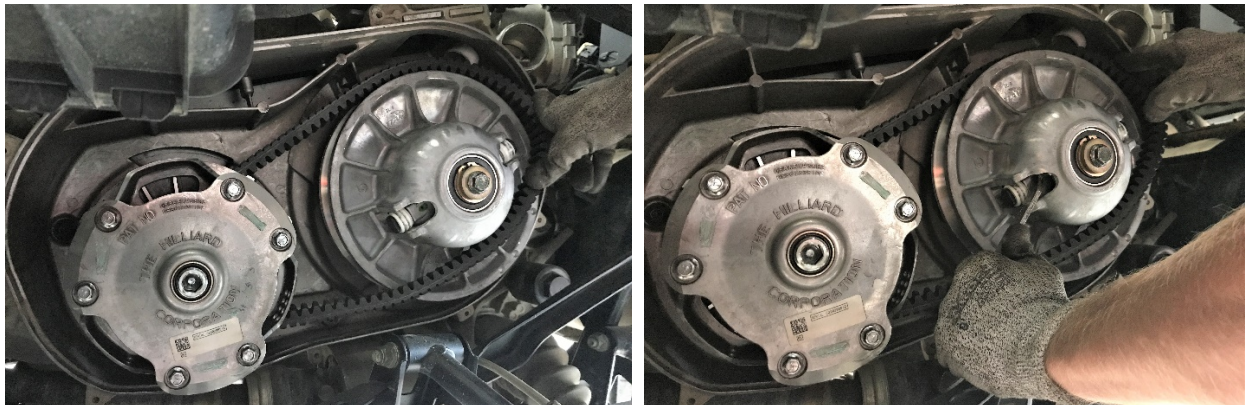

13. Install outer clutch housing. Ensure seal is good or replace.
 Note: The clutch cover screws are 6mm screws (8mm hex head) that are easy to cross thread. They screw into an aluminum back cover.



Torque spec: 100 in-lbs (8 ft-lbs). This is like a screwdriver torque. Use a hand wrench or a clutch screw gun at a low setting.

14. Install airbox to plenum hose removed in step 1.

15. Drive vehicle for 5 miles to break-in DURACLUTCH kit components.

NOTE: If the transmission shifts hard after break-in there are likely issues other than drag in the clutches. See your dealer or call DURACLUTCH service (218-967-8205).

DECALS

16. Apply two decals as shown – one on the clutch cover housing and one on the dash. Clean surface with alcohol or similar solvent. Decal application is important to alert service technicians that the standard Polaris clutches have been replaced.

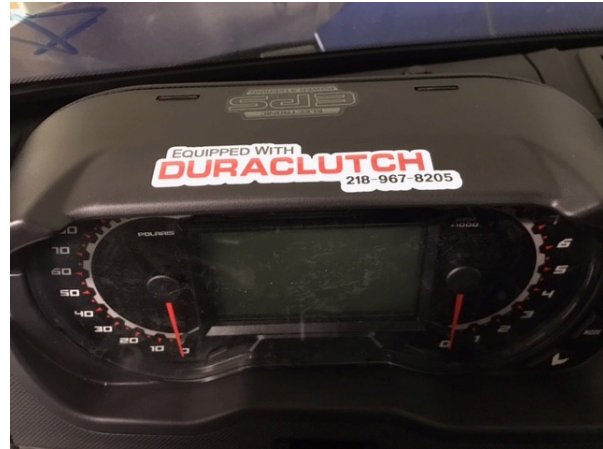

For installation video go to www.duraclutch.com