

POWERMADD® Throttle Extension Kit

Installation Instructions for Throttle Extension Kit Part No. 43592

TOOLS REQUIRED:

- Pliers
- No. 1 Phillips Screw Driver
- 8mm Wrench
- 10mm Wrench

HARDWARE INCLUDED:

Item	Qty	Description
1	2	Junction Box Halves
2	1	Junction Slide
3	4	Self-Threading Screws
4	3	Retaining Clips (1 Extra)
5	1	Cable
6	4	Cable Ties
7	1	Low-Temp Grease Pack



WARNING: Read all instructions before installing Extension Kit. Snowmobile should not be running while installing or making any adjustments to the Extension Kit. PowerMadd also recommends using a tether cord for the safest operation of your snowmobile. If at anytime you suspect there is a problem with the throttle controls, immediately shut off snowmobile and inspect. If you are experiencing problems with our Extension Kit, contact PowerMadd for customer service.

- Step 1:** Be sure carburetor(s) are correctly in sync and set up. If snowmobile is not running properly before installing Extension Kit, the snowmobile will not run correctly after installing Extension Kit.
- Step 2:** Remove stock cable from throttle lever. Then remove the stock cable from the throttle block by removing the retaining clip holding the cable to the throttle block. Some stock throttle cables do not use a retaining clip and simply snap out of the throttle block.
- Step 3:** Remove handlebar pad and any cable ties that are holding the stock throttle cable to the handlebar assembly.
- Step 4:** Install one of the retaining clips from the kit on the stock cable, and one on the ball end of the extension cable. **Refer to Illustration A** and junction box detail photo on page 2.
- Step 5:** Use the enclosed low temperature grease pack to lightly coat the inside of both junction box halves and all surfaces of the slide.
- Step 6:** Place the slide in one of the junction box halves, along with the stock cable and the extension cable as shown in the **Illustration A**. Line up the tongue of the upper box half with the groove of the lower box half, close up the junction box and install the screws. Slide rubber boot over assembled junction box.
- Step 7:** Install the extension cable into the throttle block and throttle lever in the reverse order that the assembly was taken apart.
- Step 8:** Secure the cable extension to the handlebars using the cable ties and route the stock throttle cable under the hood so it doesn't come into contact with any moving parts.
- Step 9:** Lengthen or shorten the cable adjuster on the new extension cable to set the throttle lever free play.

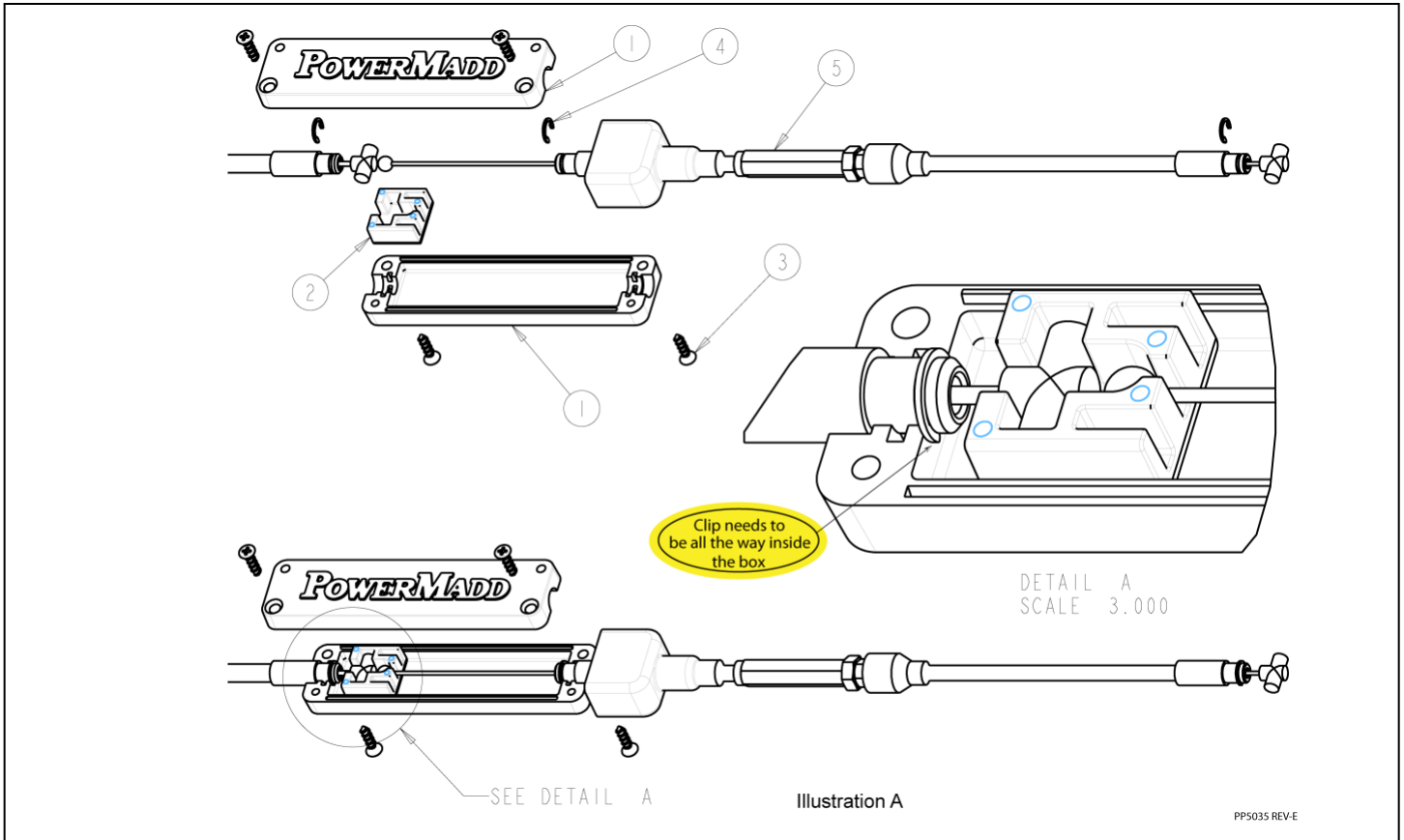

PM13592 - PowerMadd Throttle Cable Extension
Junction Box Detail

Note - "c" clips are all the way inside the junction box, not in the groove.



WARNING: Before starting the engine of this machine make certain that the throttle lever has the correct amount of free play by referring to the Owner's Manual. Check that the throttle is operating properly by opening and closing the throttle several times. Make certain the throttle returns to the idle position before starting. Raise the track completely off the ground using a secure track lift stand the first time the machine is started after installing the Throttle Extension Kit. Doing this will guard against the machine speeding off from improper throttle cable adjustment or the throttle not returning to idle.

LIMITED WARRANTY

POWERMADD warrants this product to be free from defects in material and workmanship under use for the purpose it was intended. POWERMADD shall not be liable for damage or injury caused by defective materials or workmanship. POWERMADD may elect to repair or replace this product, but is the sole judge of any defects in their product. This warranty does not cover any labor costs to remove or reinstall this product and is effective for one year from the original purchase date.