

RFE-TCCREG-OS19



Oversize valve repair for worn TCC regulator bore.

The Tool Kit required to install is: **RFE-TCCREG-TK19**

1. Remove and discard the TCC regulator valve and spring. Save the end plug and retainer clip.

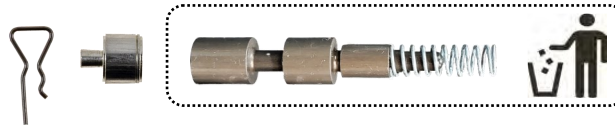

2. Insert reamer into bore without spinning it, far enough to engage **both** non cutting pilots as shown.

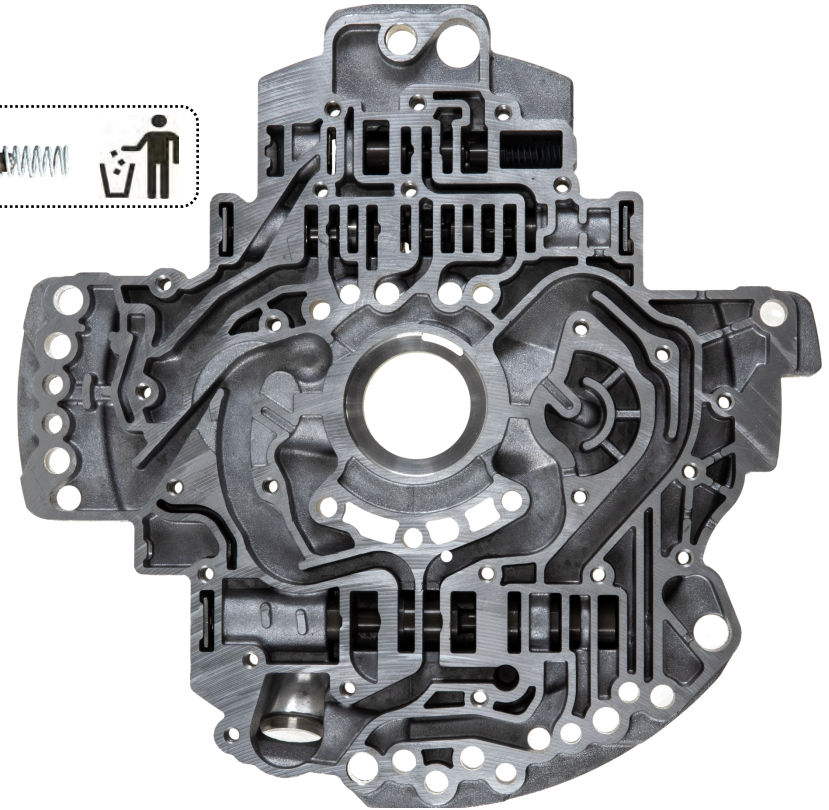
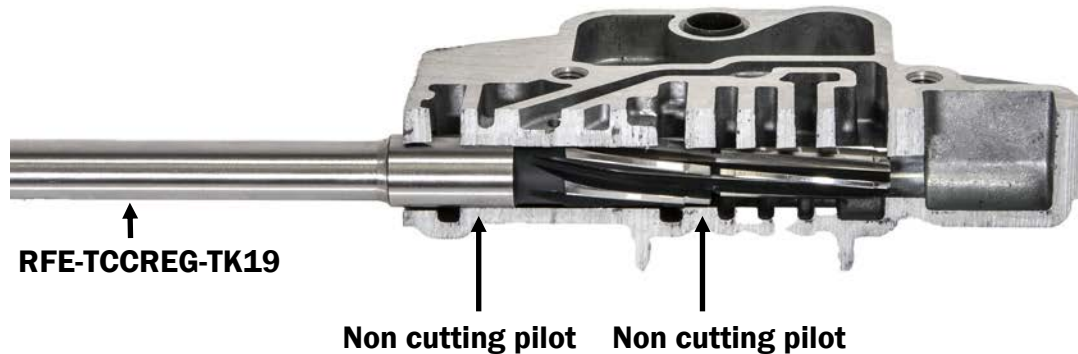

3. Using lots of WD-40® and **low speed** on your favorite portable drill, let the reamer do the cutting until it bottoms in the bore. Don't force the reamer. Bore finish and reamer life require a slow inward movement and lots of WD-40®.

4. Once reamed, clean the bore and the new TCC regulator valve furnished in this kit. Test fit to make sure the valve is free in the bore. Lube and install the **new TCC regulator valve and new spring** followed by the end plug and retainer clip.

