



2013+ FORD FOCUS ST TOURING EDITION EXHAUST INSTALLATION GUIDE

Thank you for purchasing the **AWE Non-Resonated Touring Edition Exhaust System** for the **2013+ Ford Focus ST 2.0T**. For up-to-the-minute fitment information, be sure to visit the Ford Focus section of the [AWE website](#).

As always, AWE Performance Specialists are standing by for any questions, at 215-658-1670, or email us [here](#).

Let's go!

PARTS LIST



INSPECT ALL PARTS PRIOR TO DISASSEMBLY OF VEHICLE; IF DAMAGED OR MISSING, PLEASE CONTACT THE PLACE OF PURCHASE IMMEDIATELY.

Non-resonated Touring Edition Exhaust Parts:

- 1 Non-Resonated front section (part ZR)
- 1 Over-axle pipe (part YP)
- 1 180 Technology® rear section (part YQ)
- 2 4.0" Tips (choice of color)

Hardware Kit:

- 2 3.00" Accu-Seal clamps
- 2 3.12" T-bolt clamps
- 2 M8-1.25x35mm Hex Bolts
- 4 M8 Washers
- 2 M8-1.25 Lock Nuts
- 2 Hanger clamps
- 1 Allen wrench

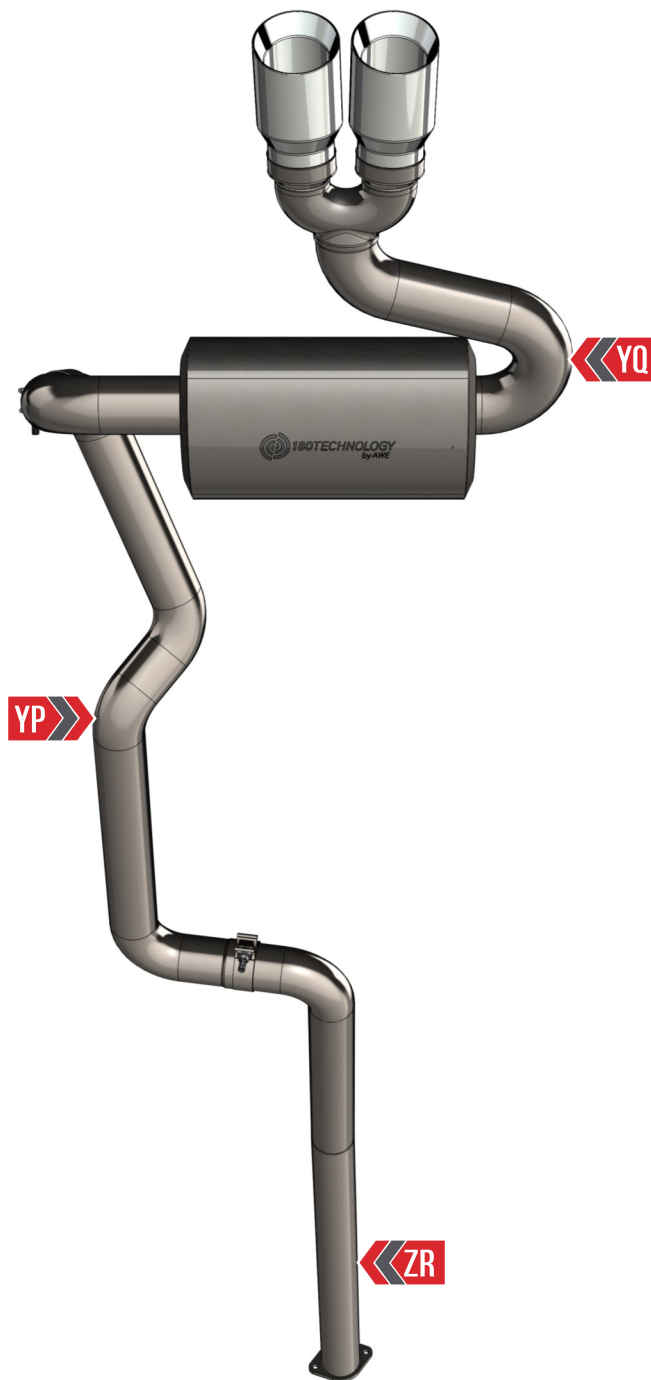

STEP 1



The factory exhaust must be **CUT** from the car to install the AWE Performance Exhaust System. Reinstalling the factory exhaust will require the use of a sleeve clamp.



Always refer to the manufacturer service manual for precise torque specifications on all OEM fasteners.

Before cutting the factory exhaust, it is recommended to spray all of the exhaust hanger bushings and both exhaust flange bolts with a penetrant oil to make removal as easy as possible.

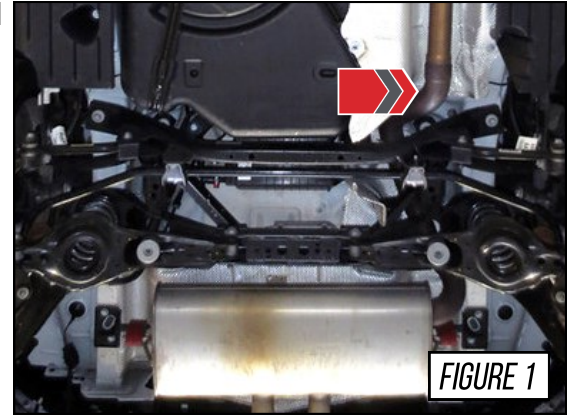

FIGURE 1

Cut the exhaust at the area located just after the welded joint, shown by the arrow in **Figure 1**.

STEP 2



WARNING: If floor jacks are being used, instead of a lift, it may be difficult to remove and/or install the components that go through the rear axle area. **DO NOT** exceed the limitations of floor jacks and jack stands.

Support the rear muffler assembly so the hanger bushings can be removed from the posts.

Pull the bushing away from the post, shown by the arrow in **Figure 2**.

Remove the rear section from the car.

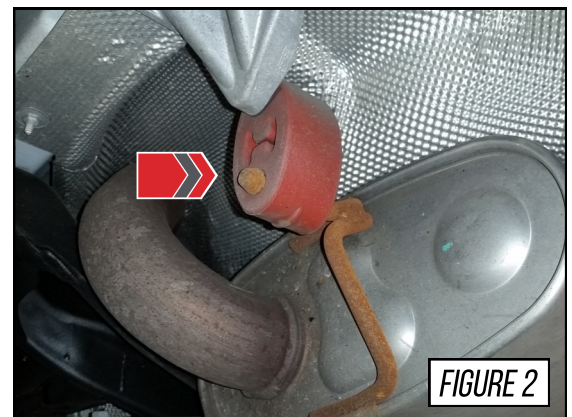

FIGURE 2

STEP 3

Loosen and remove the nuts that secure the exhaust flange in place, shown by the arrows in **Figure 3**.

The remainder of the factory exhaust can now be removed from the vehicle.

Be careful not to damage the factory flange gasket, this part is reused on the AWE Performance Exhaust.

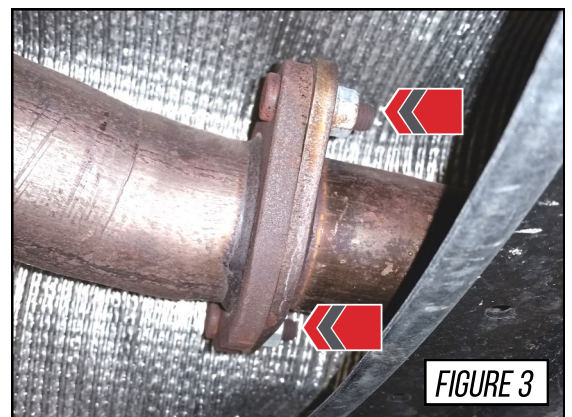

FIGURE 3

STEP 4

Install the non-resonated front section (part **ZR**), reusing the factory gasket and supplied M8 hardware.

Install the over-axle section (part **YP**) onto the front section outlet using one (1) of the included 3.0" Accu-Seal clamps. Orient the clamp to the same side as the hanger, as shown by **Arrow A** in **Figure 4**. During normal usage, the exhaust will expand toward the rear of the car, this orientation prevents any contact with the shielding.

The exhaust hanger bushing should be slightly forward when the section is installed correctly, as shown by **Arrow B** in **Figure 4**.

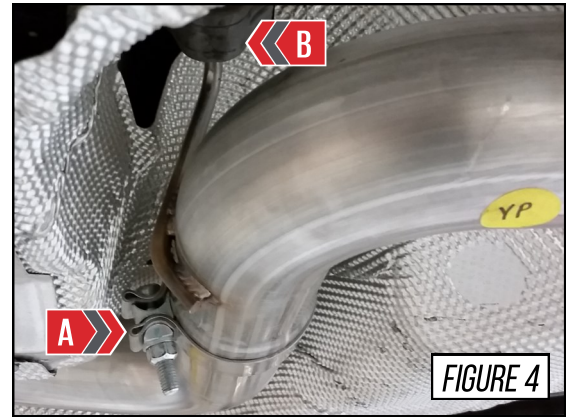

STEP 5

Install and fully seat the 180 Technology® rear section (part **YQ**) onto the over-axle pipe outlet with the included 3" Accu-Seal Clamp.

Fully seat the pipe and insert each hanger into the appropriate hanger bushing. Each hanger bushing should be slightly forward in-vehicle, as shown by the arrow in **Figure 5**.

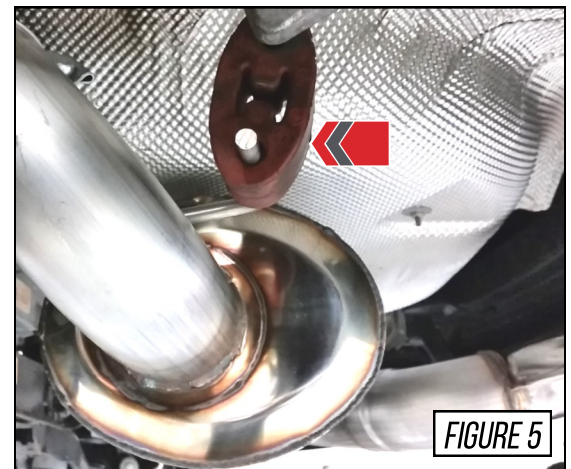

STEP 6

It is crucial to install each section and Accu-Seal clamp correctly to prevent loose joints and exhaust leaks between the tubing connections.

Arrow A in **Figure 6** shows the expanded pipe and the preinstalled Accu-Seal clamp being brought up to the corresponding pipe.

Arrow B in **Figure 6** shows the overlapping pipe installed correctly over the corresponding pipe.

Arrow C in **Figure 6** shows the Accu-Seal clamp being brought to the edge of the expanded pipe.



NOTES:

- Do not torque any Accu-Seal clamp until the entire exhaust has been installed and adjusted.
- Torque specification is a minimum of 40 ft/lbs.

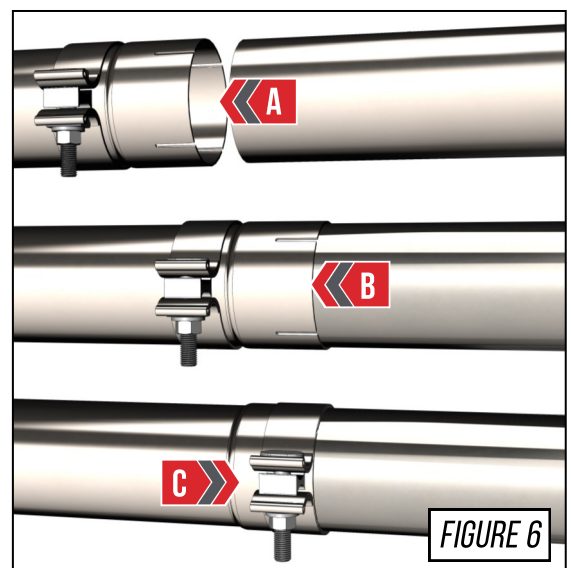

STEP 7

Install each exhaust tip with the included T-bolt clamps, but do not torque until the exhaust system has been fully adjusted and tip placement is satisfactory.

With the entire exhaust system aligned, and each clamp positioned away from the chassis to avoid any rattles, tighten and check all hardware to complete the installation, **Figure 7** shows where to start and finish.

Torque the Accu-Seal clamps to a minimum of 40 ft./lbs.



NOTE: Arrow A in **Figure 7** is an adjustment point to provide adequate spacing for the exhaust tip location.



STEP 8

To accomplish the best tip fitment, align the 2.25" tip clamp to cover *only* the slot, as shown by **Arrow A** in **Figure 8**.

The clamp should only be covering the section of the tip that has been slotted, as shown by **Arrow B** in **Figure 8**.

Torque the tip clamp to a minimum of 11 ft./lbs.



NOTE: It is recommended to apply anti-seize to the threads to prevent thread binding, shown by **Arrow C** in **Figure 8**. Additionally, it is okay to have the clamp extend beyond the edge of the tip inlet.

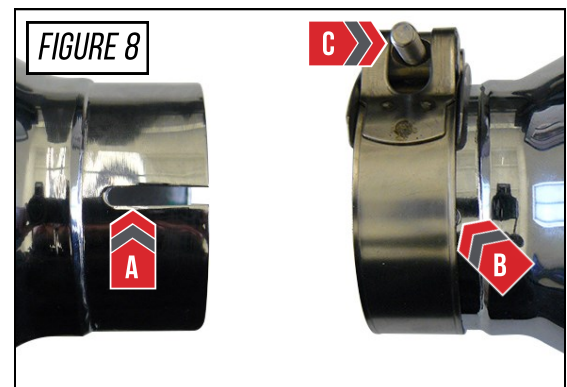

STEP 9

Install an included hanger post clamp on each of the rear muffler hanger posts, as shown at the arrow in **Figure 9**. Slide the clamp onto the hanger post so that it sits snug against the rubber hanger, and then tighten down with the enclosed Allen wrench.

These clamps will keep the exhaust from sliding laterally under usage and will keep the tips properly aligned in the valance opening.

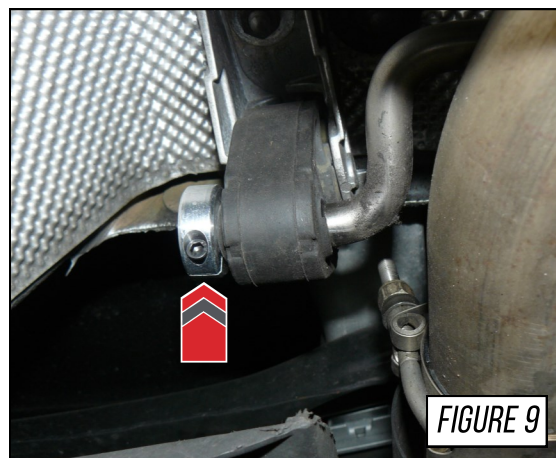

ENJOY!



CARE

Once installed properly, the AWE Performance Exhaust will provide years of trouble-free performance.

The exhaust volume and sound will settle with usage; 800-1000 miles is required to break-in new exhaust systems.

Also please note that the rear **180Technology®** resonator has a small drain hole to allow condensation to escape. Water drops from this area are normal.

Periodic cleaning of exhaust tips is necessary to maintain proper finish, especially in areas prone to road salt and caustic deicing solutions. Use a mild soap and water solution or car wax to clean the finish. Avoid using metal polishes, as they can scratch the finish.

Any questions or comments,
please do not hesitate to contact us:

AWE

199 Precision Drive
Horsham, PA 19044

215-658-1670

performance@AWE-Tuning.com

WARRANTY

Summary:

This warranty is in place for all AWE brand products, and works in conjunction with any incremental specific product warranties or guarantees as listed on AWE-Tuning.com. This warranty protects against manufacturer defect. A performance car is only as strong as its weakest link. Therefore, it is vital that you maintain your vehicle to factory specifications. By installing or using the purchased product, the Consumer accepts this warranty and any specific Manufacturer warranties enclosed. The following warranty is valid only in the United States and Canada. The Manufacturer's full warranty applies to all products sold.

Covered:

All AWE brand products against manufacturer defect. Please note that special order items are not returnable.

Period:

Secor Ltd. (AWE) warrants this **Non-Resonated Touring Edition Exhaust System** for the **2013+ Ford Focus ST 2.0T** to the original retail purchaser (Consumer) against manufacturer's defects as follows: **ONE (1) YEAR on exhaust tip finish, LIFETIME on balance of parts**, from purchase date from AWE directly or from an AWE authorized retailer. Proof of purchase will be required.

Condition of system:

In the event of a return, product must be returned with no signs of abuse, incorrect installation, forced installation, motorsports usage, or product altering whatsoever. Actions will be granted upon receipt of product at AWE, after inspection.

Action:

Returns and warranty claims MUST BE HANDLED THROUGH ORIGINAL LOCATION OF PURCHASE. Upon verification of warranty coverage, AWE will, at its sole option, repair, replace or consult toward remedy for the defective product, without charge. This is the only remedy the Consumer has for any loss or damage, however arising, due to nonconformity in or defect of the product. This warranty does not cover consequential damage, loss of time or revenues, labor, inconvenience, loss of use of vehicle, shipping, damage to the vehicle or components, or other incidental or indirect damage.

Labor:

Labor is not covered.

Shipping:

Shipping charges are not covered.

Restocking:

AWE reserves the right to charge a 20% restocking fee for products that are returned.

Exclusions:

Use of product in Motorsports or Racing conditions is grounds for warranty denial. Motorsports and Racing is an inherently abusive operational condition, and it is impossible to warranty for this type of usage. Warranties may be voided if product is not installed by an authorized AWE dealer. Warranties will be voided if product is improperly serviced, modified, or used in a way not intended by the Manufacturer. The Consumer is responsible for ensuring that the product is installed in a safe and proper manner, and should cease usage of the product immediately if an unsafe or improper condition is noted. If an unsafe or improper condition is noted, the Consumer should then immediately contact the facility where the product was installed, or AWE.

Other:

EXCEPT AS EXPRESSLY SET FORTH ABOVE, AWE MAKES NO WARRANTY, EXPRESS OR IMPLIED, AS TO ANY MATTER WHATSOEVER INCLUDING ANY IMPLIED WARRANTY OF MERCHANTABILITY OR FITNESS FOR A PARTICULAR PURPOSE. IN NO EVENT SHALL AWE BE LIABLE FOR ANY SPECIAL, INCIDENTAL, INDIRECT OR CONSEQUENTIAL DAMAGES HOWEVER CAUSED, ON ANY THEORY OF LIABILITY, AND WHETHER OR NOT AWE HAS BEEN ADVISED OF THE POSSIBILITY OF SUCH DAMAGES. AWE's sole liability on any claim of any kind, whether in contract, tort, or otherwise, for any loss or damage arising out of, connected with, or resulting from the manufacture, sale, delivery or use of the products sold hereunder shall in no case exceed the amount actually paid to AWE for the applicable product. These limitations shall apply notwithstanding any failure of essential purpose of any limited remedy.