



INSTALLATION GUIDE: AWE EXHAUST SUITE FOR THE FORD EXPLORER ST

For up-to-date fitment information, please visit the product page on [AWE-Tuning.com](https://www.awe-tuning.com).

THIS GUIDE IS INTENDED FOR THE FOLLOWING PART NUMBERS:

3015-42625 AWE Touring Edition Exhaust for Ford Explorer ST - Chrome Silver Tips

3015-43625 AWE Touring Edition Exhaust for Ford Explorer ST - Diamond Black Tips

Welcome to the AWE family, and congratulations on your purchase of the AWE Exhaust System for the Explorer ST.

Exquisite build quality and craftsmanship, coupled with industry leading performance, distinguish this exhaust system from all others.

*For up to the minute fitment information, be sure to visit the AWE website. As always, AWE Performance Specialists are standing by for any questions, [right here](#).

PARTS LIST (TOURING SYSTEM)



Inspect **ALL** parts prior to disassembly of vehicle; If damaged or **MISSING**, please contact the place of purchase immediately.

Symbol	Part Number	Description	QTY
	F86	Ford Explorer Downpipe adapter	2
	F87	Ford Explorer DS Front Pipe	1
	F88	Ford Explorer PS Front Pipe	1
	D27	X-Pipe Various Fitment	1
	F89	Ford Explorer DS Resonator section	1
	F90	Ford Explorer PS Resonator section	1
	F91	Ford Explorer DS Axle Tube	1
	F92	Ford Explorer PS Axle Tube	1
	F93	Ford Explorer DS HR Section	1
	F94	Ford Explorer PS HR Section	1
	F95	Ford Explorer DS Tip Section	1
	F96	Ford Explorer PS Tip Section	1
A >>	180250	AWE 2.5" Band clamp, stainless	2
B >>	180300	AWE 3.0" Band Clamp, Stainless	10
C >>	SEC75	3" Barrel Clamp (Bubble)	2
D >>	3910-41010	Hardware Kit for Integrated Clamp Style Exhaust Tips - Quad	1
E >>	3910-11012	AWE 1/2" Split Collar Clamp Kit	1
F >>	180014	77mm Inlet, 114mm OD, Integrated clamp, Chrome Silver	4
F >>	180015	4.50" OD x 3.00" ID, Slash Cut, Diamond Black, AWE Logo, Intergrated Clamp	4

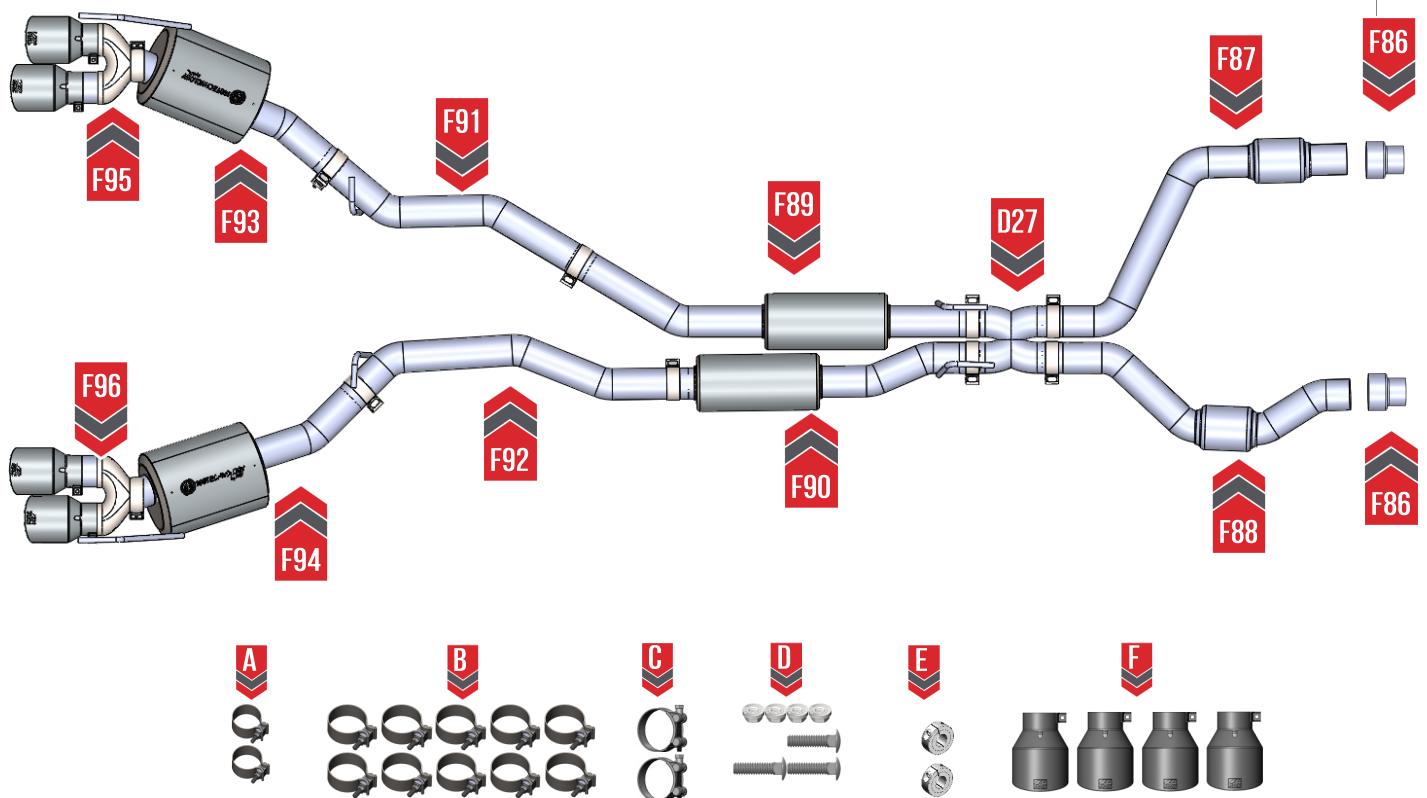



NOTE: Always refer to the manufacturer's service manual for precise torque specifications on all OEM fasteners.



CAUTION: The exhaust may be **VERY HOT** — allow adequate time for the system to cool down before disassembly. Severe burns and injury will occur if skin comes into contact with a hot exhaust system.

STEP 1



Soak all bolts and rubber hangers in penetrating oil before starting any work.

1. Loosen the OE clamps, shown at (A).
2. Remove the OE hangers, shown at (B).
3. Remove the OE hangers shown at (C).
4. Now remove the rear half of the OE exhaust system.
5. Loosen the OE clamps, shown at (D).
6. Remove the OE front pipes.

Note: All of the OE hangers will be reused with your AWE exhaust

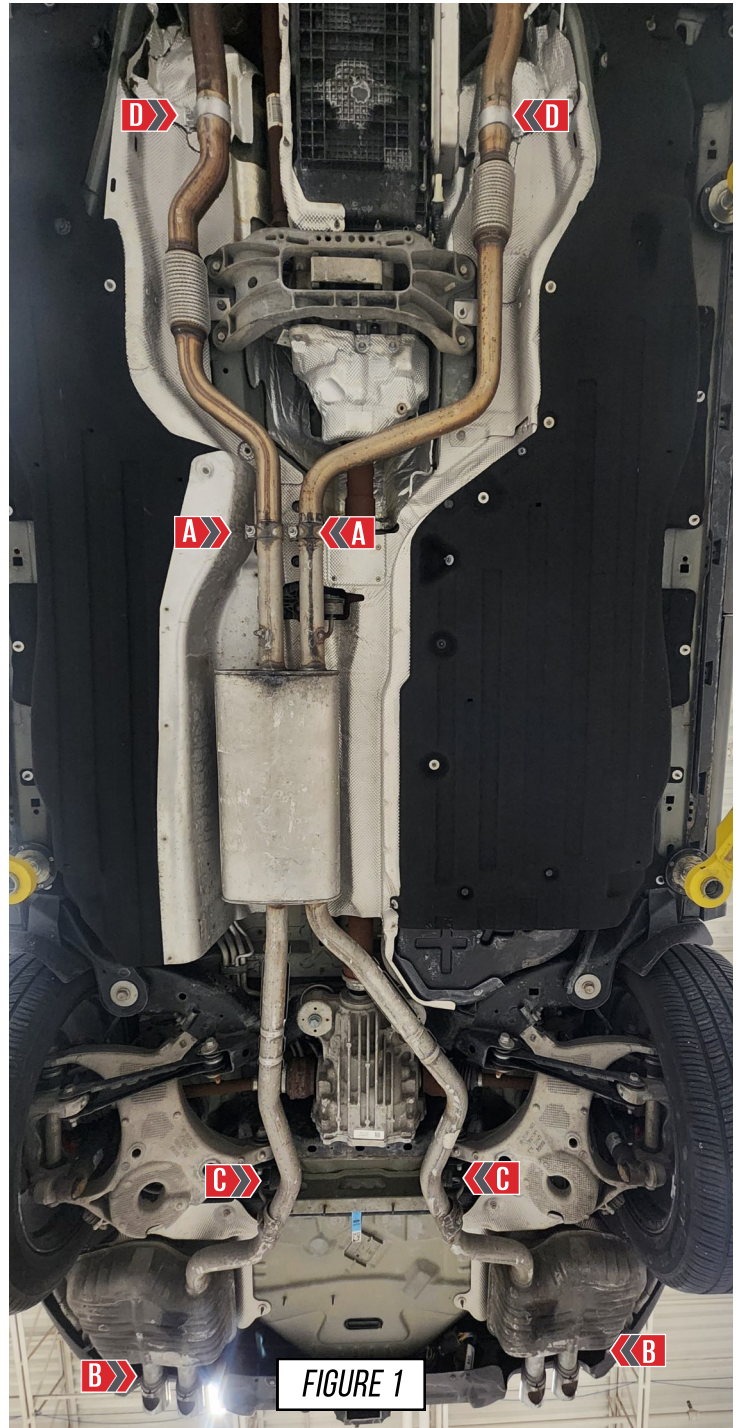

STEP 2

Remove the four OE hangers from the OE exhaust. There are 2 side specific hangers on the muffler sections, as shown in **Figure 2-1**.

There are also two in hangers in the middle of the rear section of the OE exhaust, as shown in **Figure 2-2**. These will be reused later in the installation process.

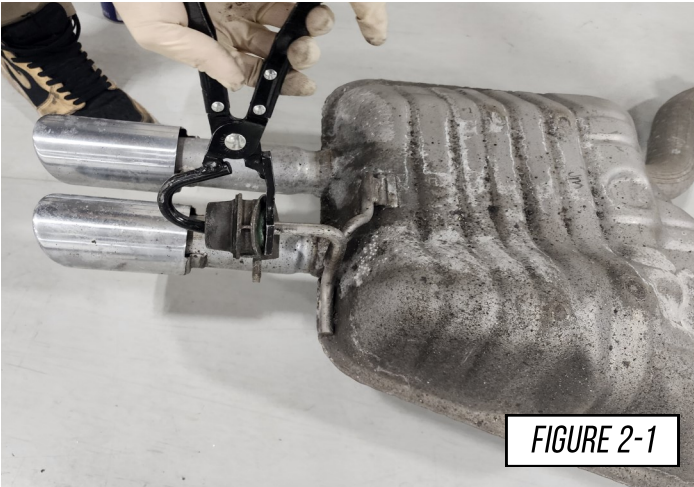

STEP 3

Install your AWE downpipe adapters (**F86**) on the driver, and passenger side downpipes as shown in **Figure 3-1**, and **Figure 3-2**.

Do this by sliding a provided 2.5" clamp over the smaller side of each adapter and bottoming out the slip fit on the OE downpipes. Fully tighten the clamps at this time.

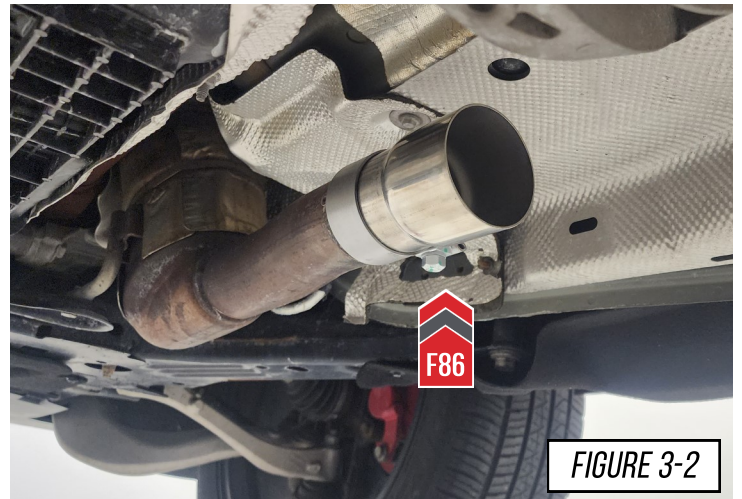
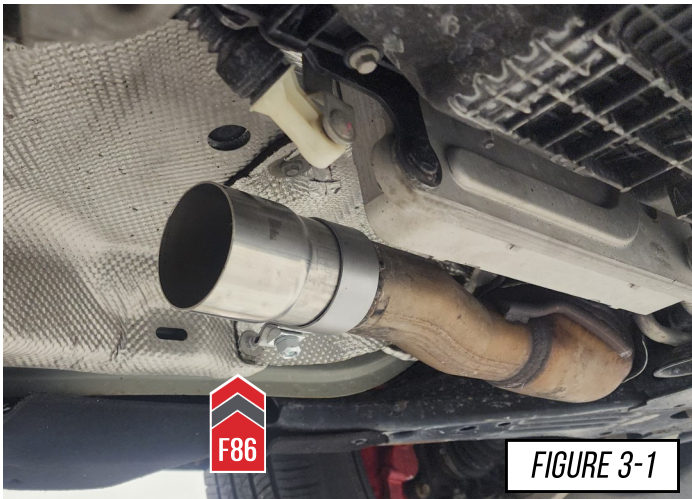

STEP 4

It is crucial to install each section and exhaust band clamps correctly to prevent loose joints, exhaust leaks and rattles.

Arrow A shows the expanded pipe and the preinstalled exhaust clamp being brought up to the corresponding pipe.

Arrow B shows the overlapping pipe installed correctly over the corresponding pipe.

Arrow C shows the exhaust band clamp being brought to the edge of the expanded pipe.



NOTES:

- **Do not** fully torque any exhaust clamp until the entire exhaust has been installed and adjusted.
- Torque specification is a **minimum** of 60 ft/lbs

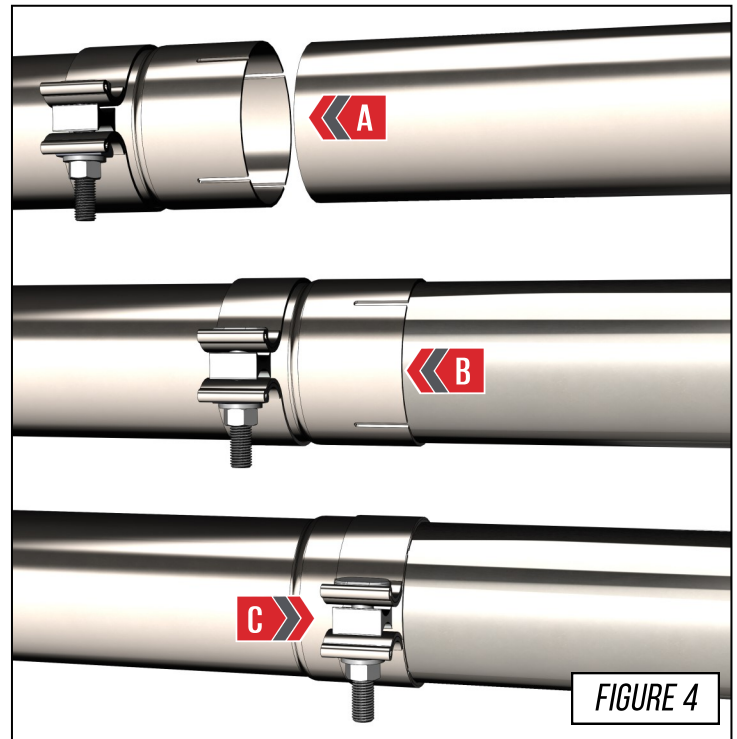

STEP 5

Install your AWE passenger side front pipe (F88), as shown in **Figure 5**. Do this by sliding a clamp over the expansion on the **SHORTER** end of the tube. Bottom out the slip fit on the AWE downpipe adapter (F86), and rotate the flex section up into the cavity.

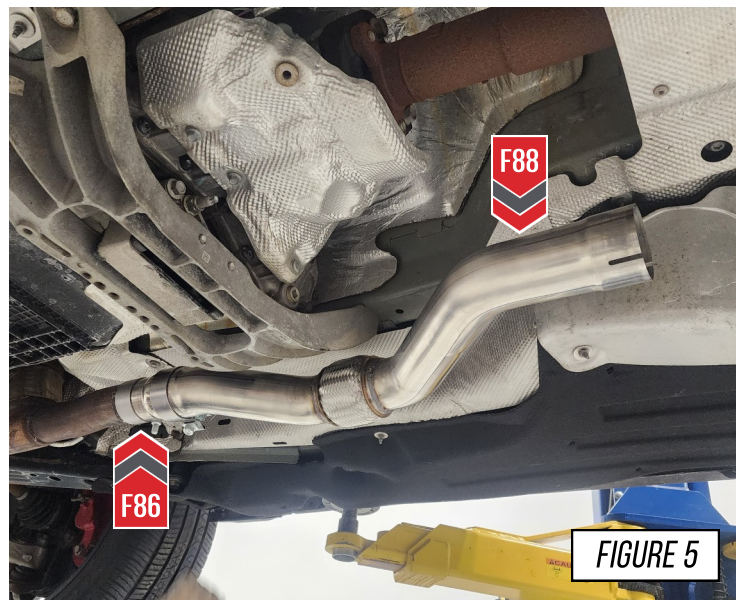

STEP 6

Install your AWE driver side front pipe (F87), as shown in **Figure 6**. Do this by sliding a clamp over the expanded end of the tube. Bottom out the slip fit on the AWE downpipe adapter (F86), and rotate the flex section up into the cavity.

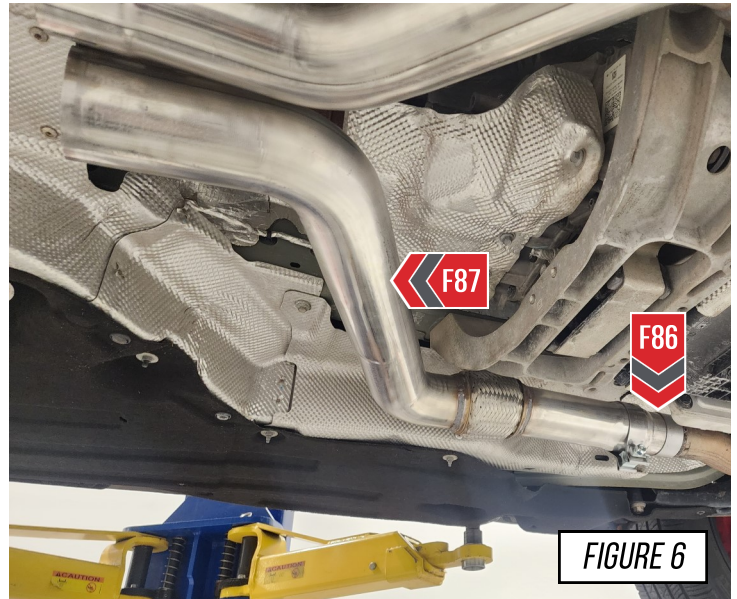

STEP 7

Install your AWE X-pipe (D27), as shown in **Figure 7**. Do this by sliding two provided clamps over the end of the front pipes. Bottom out the slip fits on the front pipes, and snug the clamps.

Next make sure your X-pipe is level. If your X-pipe is not level fitment may not be correct.

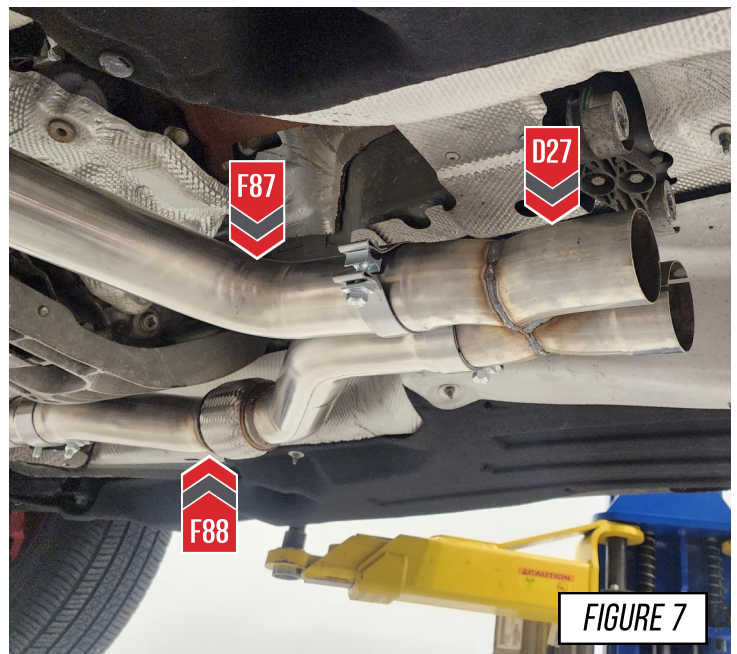

STEP 8

Install your AWE driver side resonator tube (**F89**), as shown in **Figure 8**. Slide a provided clamp over the expanded slip fit.

Now bottom out the slip fit on the X-pipe, and slide the hanger bar into the OE hanger, as shown at (**A**) in **Figure 8**.

Snug the clamp but do not fully tighten it at this time.

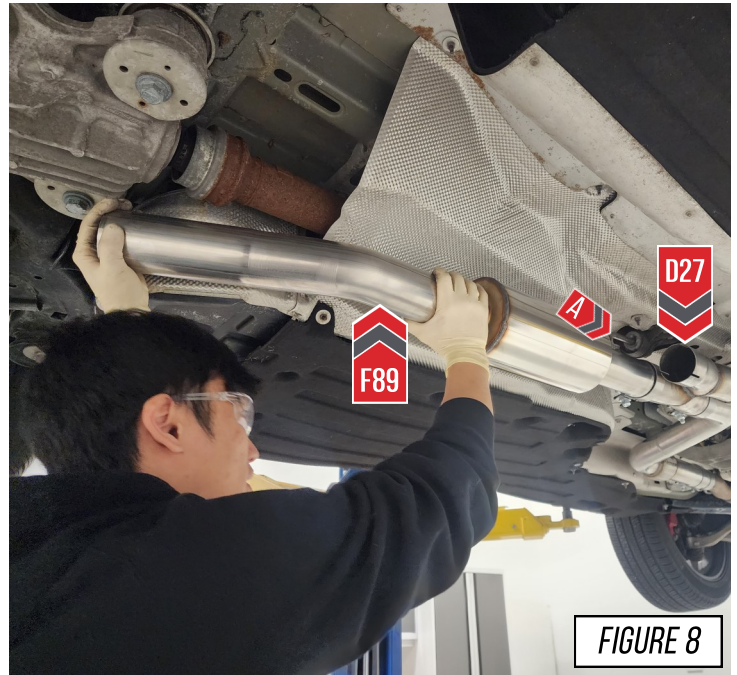

STEP 9

Install your AWE passenger side resonator tube (**F90**), as shown in **Figure 9**. Slide a provided clamp over the expanded slip fit.

Now bottom out the slip fit on the X-pipe, and slide the hanger bar into the OE hanger, as shown at (**A**) in **Figure 9**.

Snug the clamp but do not fully tighten it at this time.

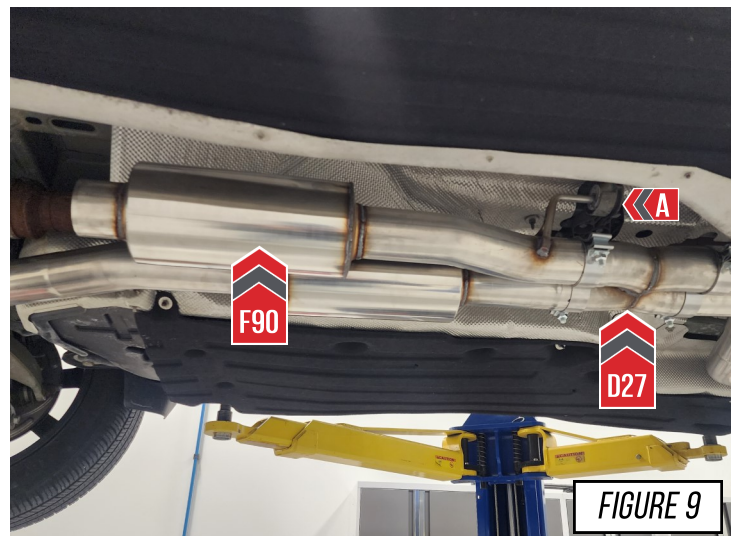

STEP 10

Install your AWE driver side axle tube (**F91**), as shown in **Figure 10**.

First slide a provided clamp over the expanded slip joint, and bottom it out on the driver side resonator tube (**F89**).

Now slide the hanger bar into the OE hanger, as shown at **(A)** in **Figure 10**.

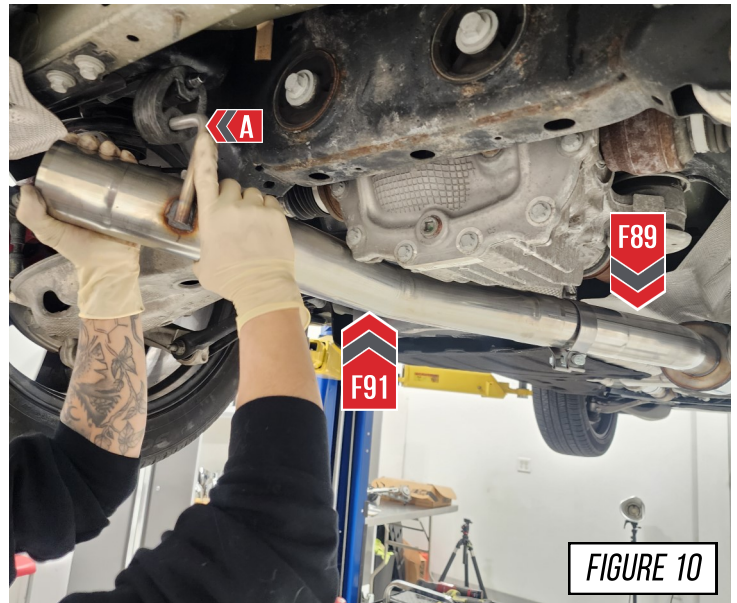

STEP 11

Install your AWE passenger side axle tube (**F92**), as shown in **Figure 11**.

First slide a provided clamp over the expanded slip joint, and bottom it out on the passenger side resonator tube (**F90**).

Now slide the hanger bar into the OE hanger, as shown at **(A)** in **Figure 11**.

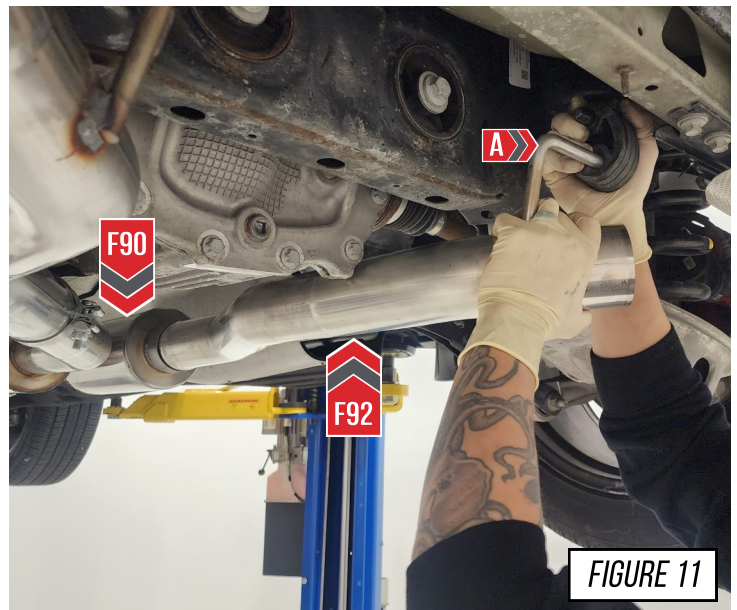

STEP 12

Gather your AWE driver side HR tube (**F93**), slide a provided clamp over the expanded end, and bottom out the slip fit onto the back of your AWE driver side axle tube (**F91**), as shown in **Figure 12**.

Next rotate the driver side outlet tube up into position, and secure it in place by reinstalling the OE hanger, as shown at (**A**) in **Figure 12**.

Snug the clamp down but do not fully tighten it at this time.



STEP 13

Gather your AWE passenger side HR tube (**F94**), slide a provided clamp over the expanded end, and bottom out the slip fit onto the back of your AWE driver side axle tube (**F92**), as shown in **Figure 13**.

Next rotate the passenger side outlet tube up into position, and secure it in place by reinstalling the OE hanger, as shown at (**A**) in **Figure 13**.

Snug the clamp down but do not fully tighten it at this time.

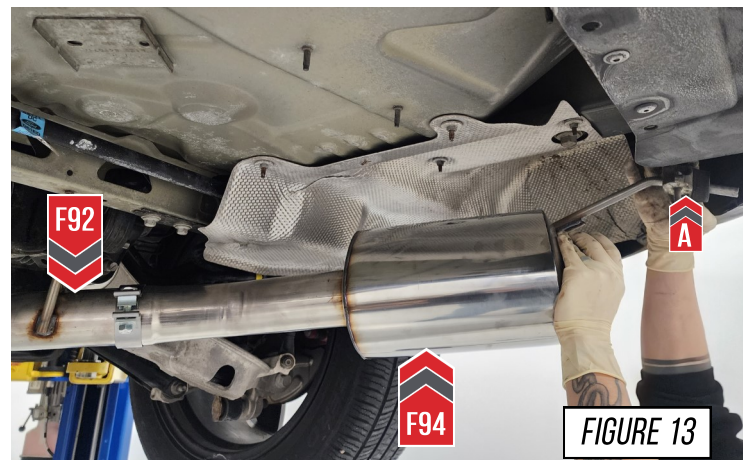

STEP 14

Gather your AWE tip outlet sections (**F95/F96**), and the two provided ball clamps.

Install your driver side tip outlet section (**F95**), as shown in **Figure 14-1**. Snug the clamp but do not fully tighten it as tip adjustments will be necessary.

Now install your driver side tip outlet section (**F96**), as shown in **Figure 14-2**. Snug the clamp but do not fully tighten it as tip adjustments will be necessary.

Note: We recommend coating the threads of the bubble clamps with anti-seize.

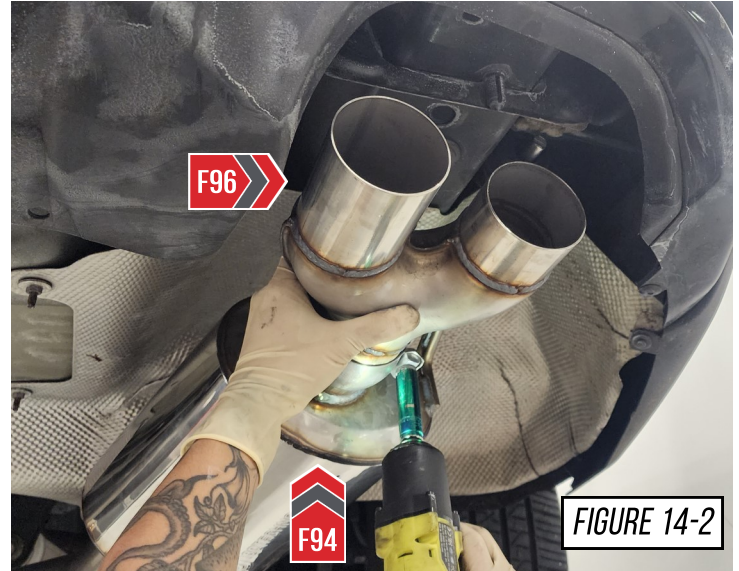

STEP 15

To install the exhaust tips with integrated clamps, first, attach the exhaust tip in the proper orientation onto the exhaust outlet tube.

Insert one of the carriage bolts from the hardware kit (**3910-41010**) through the tab on the exhaust tip and thread on one of the corresponding nuts.

Using anti-seize on the bolt threads will help installation and prevent breakage of hardware.

 If exhaust system only has 2 exhaust tips while the integrated clamp kit has enough hardware for our 4 tip exhaust systems. You will have 2 sets of hardware left over that will not be used.

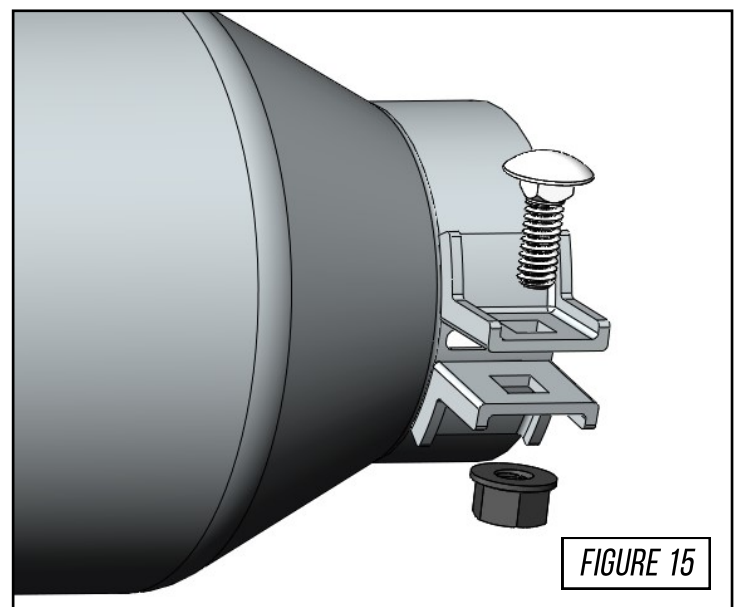

STEP 16

Now install your four tips onto your exhaust, as shown in **Figure 16**.

With your tips installed, loosen the ball clamp installed in **Step 15** and move the tips to your desired position. Now work from front clamps back fully tightening all clamps, and bolts. Ensure the tips stay in their desired position.



FIGURE 16

STEP 17

For the rear sections, hanger bar collar clamps are provided to prevent side to side movement of the exhaust system. After sliding the exhaust hanger bar through the OEM grommet, install the collar clamp on the outside end of the bar as shown in **Figure 17**.

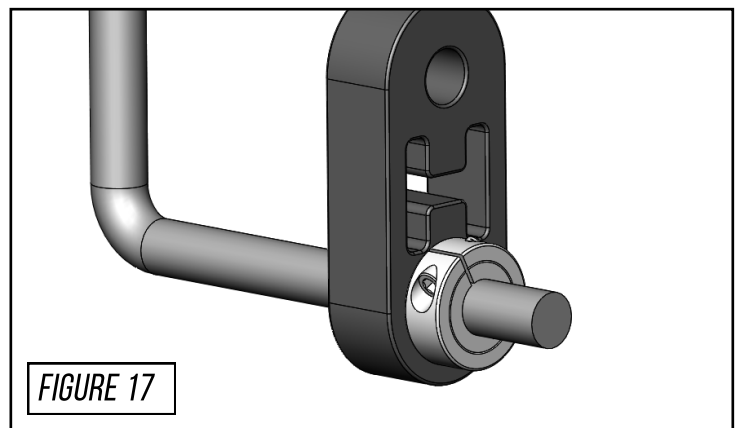

FIGURE 17

STEP 18

Install the provided lock collars on to the axle tube hanger bars, as shown in **Figure 18**.



FIGURE 18

STEP 16

With the complete AWE exhaust system installed, all clamps tightened and the tips aligned. It is now recommended to drive the car to allow the exhaust to heat cycle.



At this point the exhaust will be **very hot**, allow to cool before work continues.

With the car cooled down, check the tips for correct alignment.



Don't forget to look below for any troubleshooting needs!



ENJOY!



TROUBLESHOOTING

Issue	Solution
Exhaust is not fitting correctly	Most fitment issues are due to improperly adjusted exhaust. This includes tip fitments and rattling due to chassis contact. Check out our FAQ/ fitment guide for more installation tips.
Incorrect or missing parts	Double check the parts list for your system and compare them with what you received. Fill out our contact form, found below and let us know what parts you need.

CARE

Once installed properly, your AWE exhaust will provide years of trouble-free performance.

The exhaust volume and sound will settle with usage; 800-1000 miles is required to break-in new exhaust systems.

Also, please note that the rear **180Technology**® resonator has a small drain hole to allow condensation to escape. Water drops from this area are normal.

Periodic cleaning of exhaust tips is necessary to maintain proper finish, especially in areas prone to road salt and caustic deicing solutions. Use a mild soap and water solution or car wax to clean the finish. Avoid using abrasive polishes, as they can scratch the finish. For best results, we recommend [AWE's Fantastic Tip Tonic](#).

Any questions or comments,
please do not hesitate to contact us:

AWE
[CONTACT FORM](#)

WARRANTY

Up-to-date warranty information is found [HERE](#).