



1.877.287.8634

## **INSTALLATION INSTRUCTIONS**

**IMPORTANT NOTICE:** Be sure to inspect and test fit product before having it coated or painted. Ranch Hand will not be responsible for the cost of the coating if any problems with fit or finish are not noted and addressed beforehand.

# **2019-up FORD RANGER GRILL GUARD PART # GGF19MBL1**

**\*\*\* FOR VEHICLES WITH SENSORS, YOU WILL NEED TO USE PSF19MBP \*\*\***

1. If equipped, remove the skid plate by removing the (4) 15mm bolts.
2. Remove the (5) 10mm bolts from under the front end of the bumper.

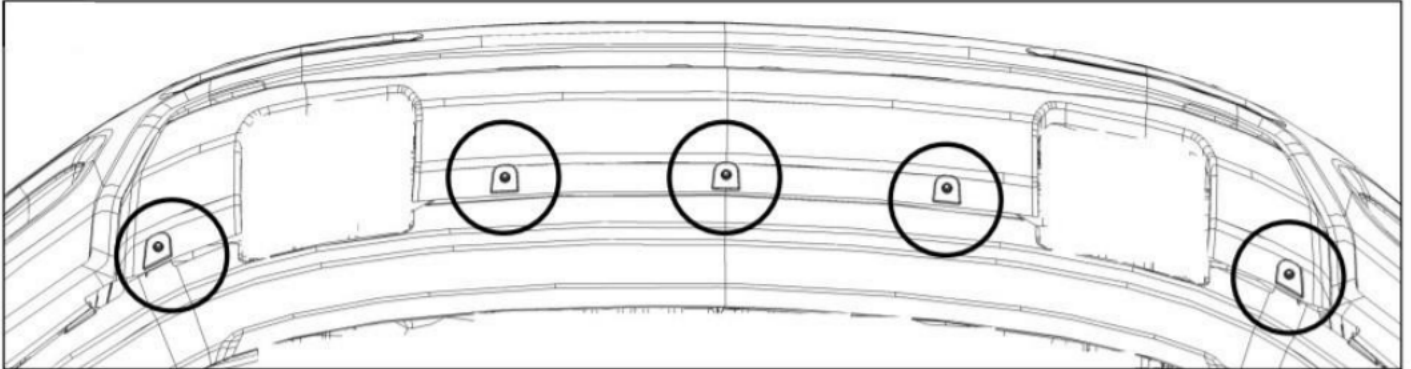

3. Remove the (2) 10mm license plate bolts and unclip license plate bracket from bumper.
4. Remove the (5) push clips located just above the bumper opening.
5. Remove the front bumper cover by pulling from the bottom up.
6. Unplug any connectors to the bumper. The connector is in the upper driver corner.



### **----- WARNING -----**

Special care should be exercised in the handling, storage and installation of Ranch Hand equipment.

The actual weight of each piece of equipment will vary depending on style and model. The weight of the equipment is sufficient in volume to warrant special care, assistance and in some instances, the use of mechanical equipment during the transfer and installation of the equipment.

Do not assume a position directly under the equipment during installation. Be sure the equipment has been connected and stabilized during installation to prevent falling or shifting of positions.

Periodically check tightness of bolts to make sure they are tight, and unlikely to fail.

Rev. 2021



1.877.287.8634

### INSTALLATION INSTRUCTIONS

**IMPORTANT NOTICE:** Be sure to inspect and test fit product before having it coated or painted. Ranch Hand will not be responsible for the cost of the coating if any problems with fit or finish are not noted and addressed beforehand.

7. On models with sensors and/or adaptive cruise, you will need to unhook the connector from its location to remove the bumper.



8. Unbolt the bumper by removing the (2) 8mm bolts, *one on each side*, front splash guard bolts and (6) 21mm bumper nuts, *three on each side*.



9. Remove the bumper.

10. Install the top mounting brackets. Mount them the two 13mm bolts on the backside of the bumper.

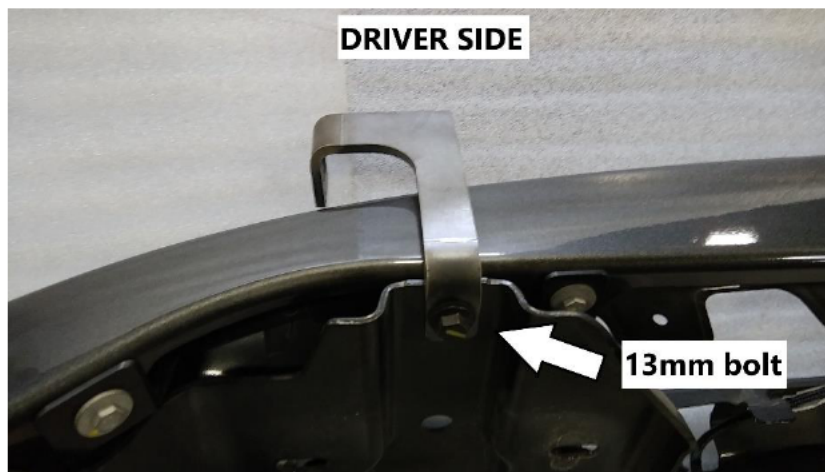

### ----- WARNING -----

Special care should be exercised in the handling, storage and installation of Ranch Hand equipment. The actual weight of each piece of equipment will vary depending on style and model. The weight of the equipment is sufficient in volume to warrant special care, assistance and in some instances, the use of mechanical equipment during the transfer and installation of the equipment. Do not assume a position directly under the equipment during installation. Be sure the equipment has been connected and stabilized during installation to prevent falling or shifting of positions. Periodically check tightness of bolts to make sure they are tight, and unlikely to fail.  
Rev. 2021





1.877.287.8634

### INSTALLATION INSTRUCTIONS

**IMPORTANT NOTICE:** Be sure to inspect and test fit product before having it coated or painted. Ranch Hand will not be responsible for the cost of the coating if any problems with fit or finish are not noted and addressed beforehand.

11. Set the top mounting brackets so that they are minimum of 36 <sup>3</sup>/<sub>4</sub>" and maximum of 36 <sup>7</sup>/<sub>8</sub>" apart.



12. Remove the tow hooks (if equipped). If no tow hooks, you will have to trim cutouts to expose the frame.



13. Reinstall the bumper.

14. On the passenger side tow hook, cut the little tab off.

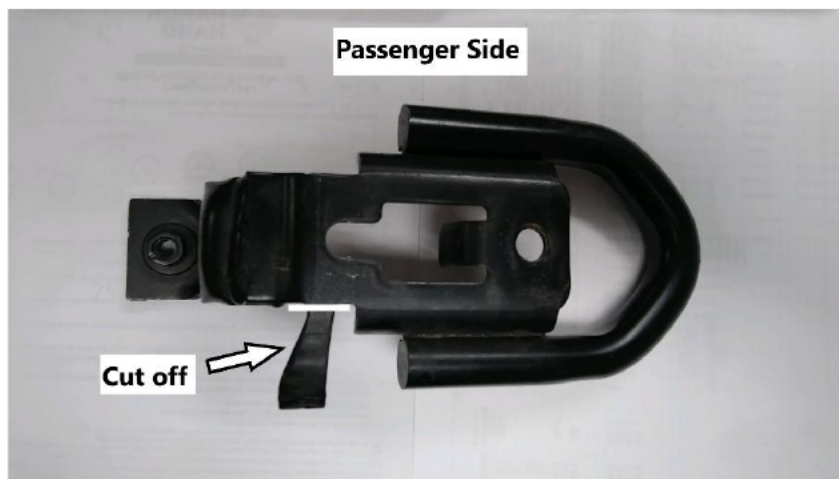

### ----- WARNING -----

Special care should be exercised in the handling, storage and installation of Ranch Hand equipment. The actual weight of each piece of equipment will vary depending on style and model. The weight of the equipment is sufficient in volume to warrant special care, assistance and in some instances, the use of mechanical equipment during the transfer and installation of the equipment. Do not assume a position directly under the equipment during installation. Be sure the equipment has been connected and stabilized during installation to prevent falling or shifting of positions. Periodically check tightness of bolts to make sure they are tight, and unlikely to fail.  
Rev. 2021



1.877.287.8634

## **INSTALLATION INSTRUCTIONS**

**IMPORTANT NOTICE:** Be sure to inspect and test fit product before having it coated or painted. Ranch Hand will not be responsible for the cost of the coating if any problems with fit or finish are not noted and addressed beforehand.

15. Install the bottom brackets and tow hooks (if equipped).

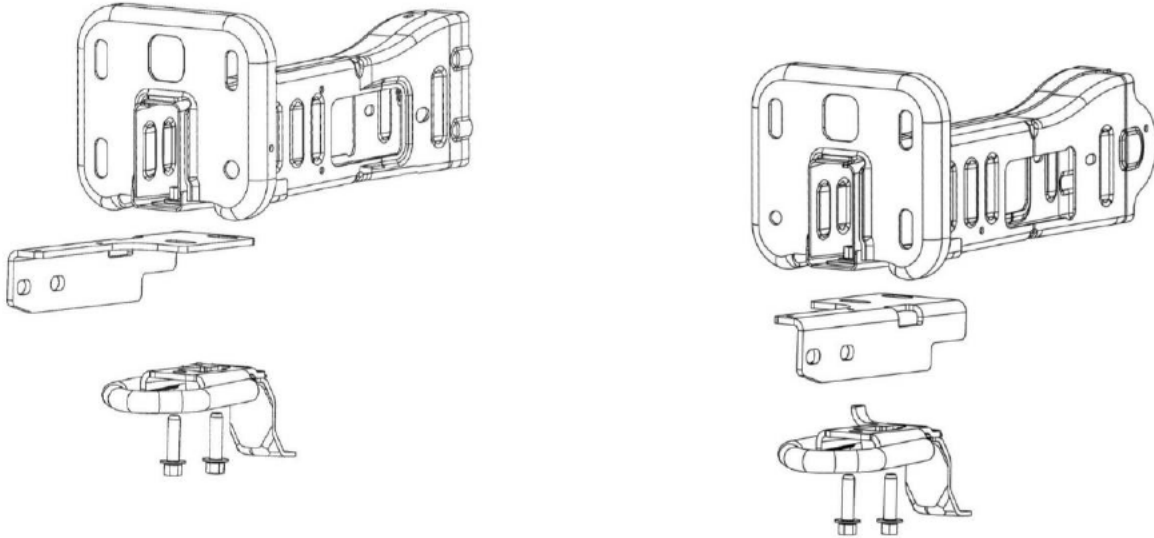

16. Loosely mount the grill guard to the bottom and top brackets using black carriage bolts, washers, and nuts.

17. Level the grill guard then tighten all bolts.

18. If vehicle does not have sensors, insert plugs into the holes in bottom channel. If sensors are present, follow instruction in PSF19MBP.

19. Make sure all nuts and bolts are tight and all wires plugged in.

### ----- WARNING -----

Special care should be exercised in the handling, storage and installation of Ranch Hand equipment.

The actual weight of each piece of equipment will vary depending on style and model. The weight of the equipment is sufficient in volume to warrant special care, assistance and in some instances, the use of mechanical equipment during the transfer and installation of the equipment.

Do not assume a position directly under the equipment during installation. Be sure the equipment has been connected and stabilized during installation to prevent falling or shifting of positions.

Periodically check tightness of bolts to make sure they are tight, and unlikely to fail.

Rev. 2021